

operative

o7



TEAM
collection

codutti

L'ufficio rappresenta la tua identità, il percorso che stai compiendo e i valori che ti accompagnano.

Comfort, tecnologia e funzionalità contribuiscono al tuo benessere e facilitano la riuscita delle attività che ti vedono protagonista nella vita lavorativa.

Noi di Codutti, dal 1954 artigiani e industriali insieme, creiamo soluzioni d'arredo per ufficio di alta gamma con l'attenzione e la cura frutto di oltre sessant'anni di esperienza nella produzione e nel design made in Italy, per le aziende, per gli studi professionali e i progetti contract, anche sui mercati internazionali.

Tutte le nostre collezioni – dagli arredi direzionali agli operativi, dalle sedute alle pareti divisorie – nascono dall'unione di artigianalità e innovazione tecnologica e si contraddistinguono dall'alto livello di qualità e cura del dettaglio propri del marchio Codutti.

La flessibilità per noi è un valore: prendiamo in carico i tuoi progetti e siamo al tuo fianco nel fornire soluzioni personalizzate che superano le tue aspettative.

Un ufficio unico e coinvolgente, che ti emoziona ogni giorno.

Your office shows who you are, what your journey is and your principles are.

Comfort, technology and functionality: all contribute to your wellness and make easier those tasks that see you as the main actor in your daily business life.

We at Codutti have been both craftsmen and industrialists since 1954; we create design solutions for the highline office, paying the attention for the detail we have learned from more than sixty years of experience with the made in Italy production and design.

It's for companies, for professionals and contract projects, also on global markets.

All our collections - from the executive to the operative office, from the chairs to the partition walls - are born from the union between craftsmanship and technology innovation, and stand out thanks to high quality level and care for details, which has always been the main distinction of the Codutti brand.

We believe flexibility is an added value: we take in your project requests and stand at your side to give you customized solutions that go beyond your expectations.

A unique appealing office that excites you day after day.

INDEX

01



Bianco | Alluminio
White | Aluminium

p. 8

02



Bianco | Bianco
White | White

p. 12

07



Rovere | Bianco
Oak | White

p. 32

08



Wengé | White
Wengé | White

p. 36

03



Bianco | Bianco
White | White

p. 16

04



Rovere | Bianco
Oak | White

p. 20

09



Perla | Alluminio
Pearl grey | Aluminium

p. 40

05



Rovere | Alluminio
Oak | Aluminium

p. 24

06



Noce | Bianco
Walnut | White

p. 28

Team

Per un ambiente ufficio che sia attuale, elegante e funzionale al tempo stesso, Codutti ha progettato le collezioni Team. L'ufficio moderno è sempre più dinamico, versatile, aggregante. Il fattore puramente tecnico operativo è importante, ma è l'uomo a essere al centro. Da qui la necessità di creare un ambiente accogliente e motivante nelle forme, nei colori e nell'ergonomia, orientandosi, con sempre maggiore attenzione, al benessere di chi ci lavora. Un layout dinamico sempre in evoluzione come le sfide del tempo reale, soluzioni originali per la condivisione degli spazi: questo promettono le collezioni Team.

Il programma Team

Progetto di arredo operativo vasto e articolato, pensato per dare una risposta alle più svariate esigenze tecniche ed estetiche. Cinque versioni, dalle linee attuali e nello stesso tempo tradizionali. La Pannellata ha il fianco in melaminico collegato al top tramite un distanziale in inox lucido. I fianchi a Ponte e Anello in tubo rettangolare sono verniciati così come quelli a T rovesciata. Completa la gamma la Conica, con gambe a sezione semiellittica in acciaio stampato. Lavoro di squadra con il system bench dal fianco a Ponte o Conico: postazioni dotate di schermi - anche in stoffa - vano tecnico in alluminio satinato, lampade, porta monitor... Garantite funzionalità, estetica ed ergonomia.

For an office environment with a contemporary feel, elegant and functional at the same time, Codutti has designed the Team collections. The modern office space is increasingly dynamic, versatile and unifying. Its purely technical and operational aspect is important, but people are the focus and that makes it necessary to create welcoming surroundings with motivating designs, colours and ergonomics, where the target has increasingly been shifted to the wellbeing of those who work there. A dynamic, constantly evolving layout, in line with real-time challenges; original space-sharing solutions: this is what the Team collections have to offer.

The Team program

Vast, well-designed operational furniture, designed to be the answer to a host of technical and aesthetic requirements. Five versions, with current styling that manages to remain within the realms of tradition. Panelled has a side in melamine, connected to the top via polished stainless steel spacer. The Bridge and Ring in rectangular piping are painted, as per the one overturned T leg. The range is completed by Conical, with semi-oval legs in moulded steel. Teamwork with the bench system alongside Bridge or Conical: workstations with screens - including in fabric - lamp, monitor stand, technical compartment in satin-finish aluminium... Guaranteed practical use, aesthetics and ergonomics.



01 WHITE | ALUMINIUM





A Top in melaminico da 18 mm con bordo in ABS.
18 mm melamine top with ABS edge.

B Allungo componibile, con moduli cassettiere, a giorno e con ante.
Modular extension, with drawer units, open units or units with doors.

C Gamba a ponte in tubo rettangolare sezione 70x30 mm.
Bridge leg in rectangular pipe (section 70x30 mm).

Finiture | Finishes

ARREDI | FURNITURE

Top scrivania e frontali | Worktops and frontals

MB29
Melaminico | Melamine
Bianco
White

Struttura | Structure

MM21
Melaminico | Melamine
Alluminio
Aluminium

Gambe | Legs

EM41
Verniciato | Painted
Alluminio
Aluminium

SEDUTE | SEATING

Fronte | Front

UR54
Lana cotta per cuoio | Boiled wool for thick leather
Rosso
Red

Retro | Back

CJ83
Cuoio | Thick leather
Bianco
White

Dati Tecnici | Technical Data

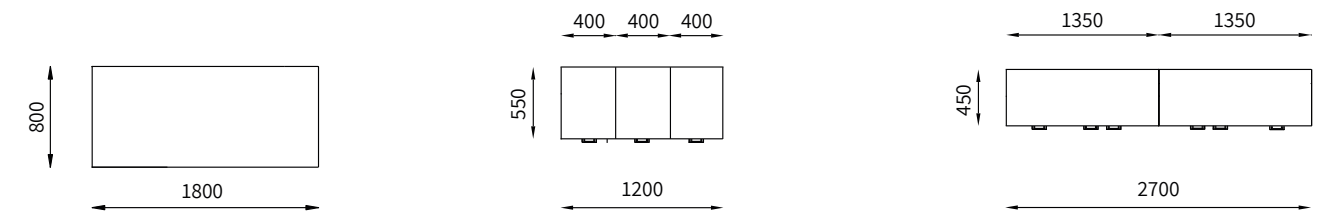

02 WHITE | WHITE





Paretina in fibra di poliestere rivestita in tessuto.

Polyester fiber panel upholstered in fabric.

Finiture | Finishes

Top Top

MB29
Melaminico | Melamine
Bianco
White

Struttura Structure

MB29
Melaminico | Melamine
Bianco
White

Gambe Legs

EB48
Verniciato | Painted
Bianco
White

SEDUTE | SEATING

Struttura Structure

Plastica | Plastic
Bianco
White

Seduta Seat

Trevira | Trevira
Blu
Blue

Dati Tecnici | Technical Data

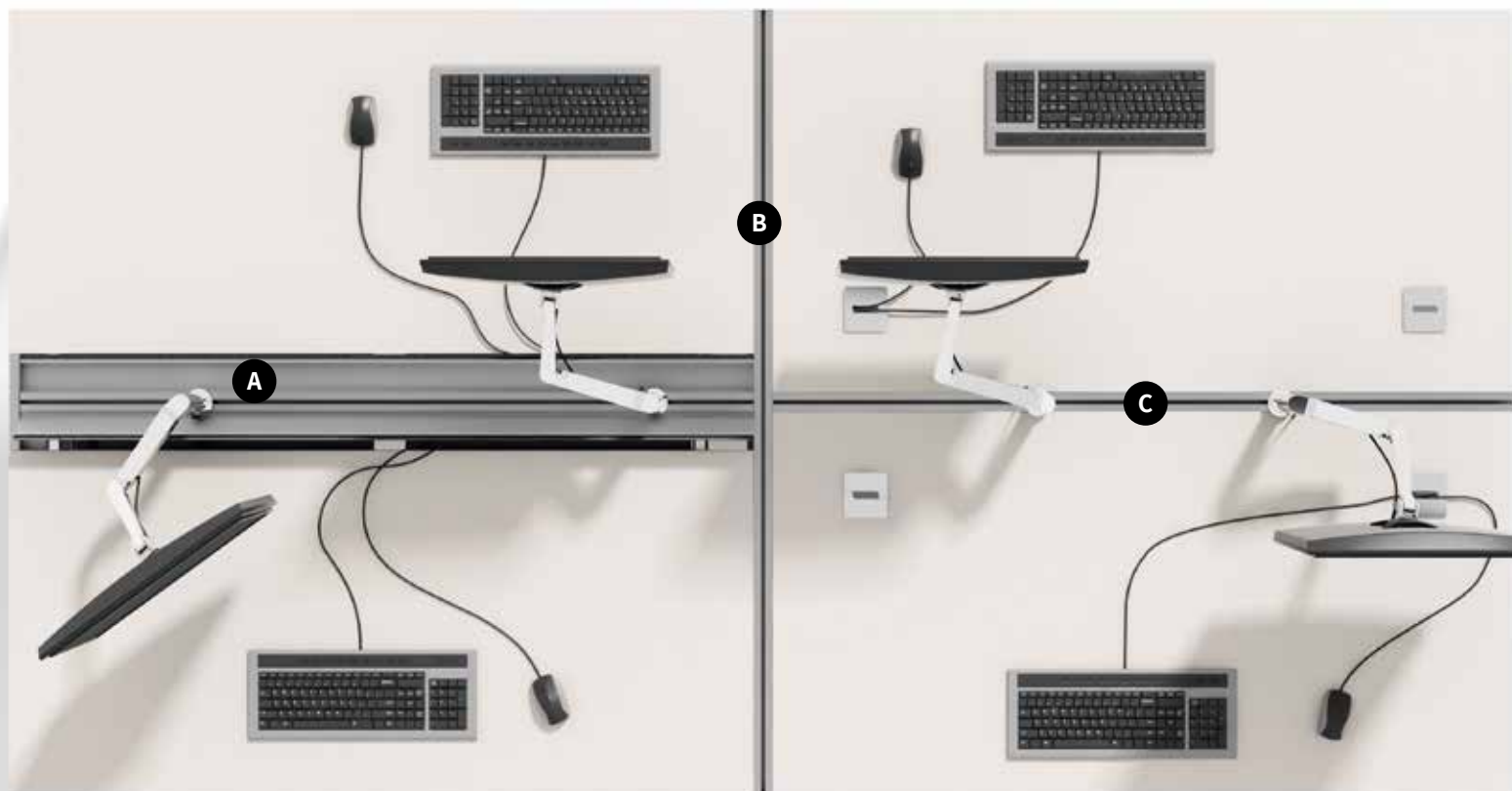
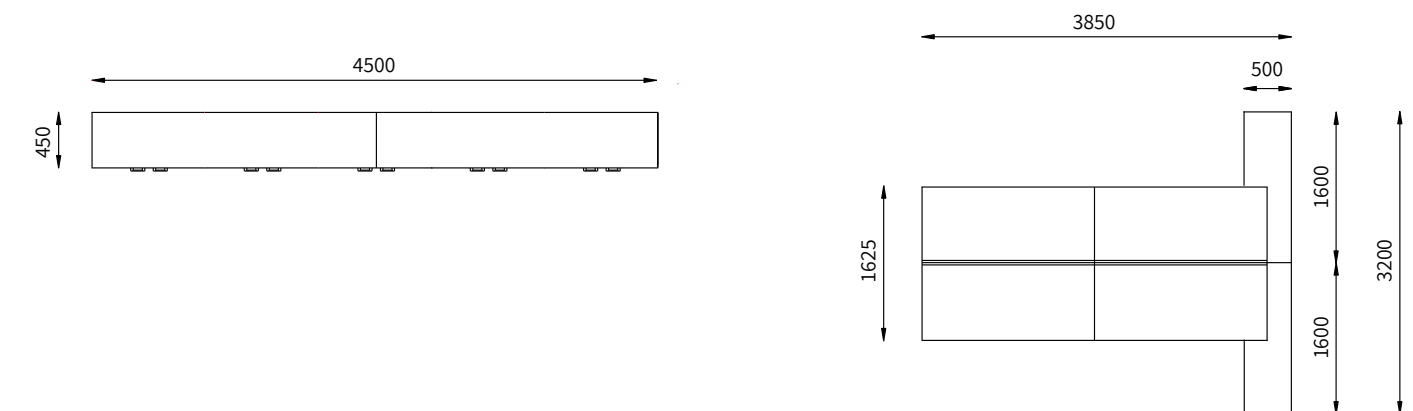

A Versione fascia tecnica composta da binario di aggancio e due sportelli passacavo longitudinali in alluminio anodizzato canalizzati.

Technical band version consisting of connecting track and two lengthways cable duct hatches in anodised aluminium.

B Binario trasversale in alluminio anodizzato, opzionale, attrezzabile con paretine, lampada e supporto monitor.

Crossways track in anodised aluminium, optional, to be equipped with panel, lamp and monitor support.

C Versione con binario di aggancio in alluminio anodizzato con 2 passacavi in ABS color alluminio canalizzati per ciascun top.

Version with track for hooking in anodised aluminium with 2 ducts in ABS, aluminium colour, ducted to each top

03 WHITE | WHITE



Dati Tecnici | Technical Data

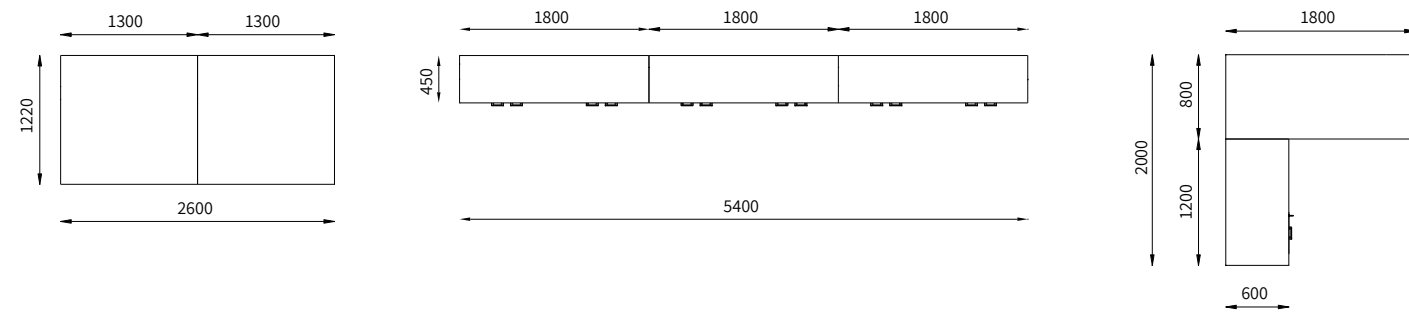

Finiture | Finishes

ARREDI | FURNITURE

Top scrivania e frontali | Worktops and frontals

MB29
Melaminico | Melamine
Bianco
White

Struttura | Structure

MB29
Melaminico | Melamine
Bianco
White

Gambe | Legs

EB48
Verniciato | Painted
Bianco
White

SEDUTE | SEATING

Fronte | Front

CN72
Cuoio | Thick leather
Nero
Black

Retro | Back

CJ83
Cuoio | Thick leather
Bianco
White



A Top in melaminico da 18 mm con bordo in ABS.
18 mm melamine top with ABS edge.

B Sottomano in metallo verniciato rivestito in cuoio con cuciture a punto sella.
Painted metal desk pad covered in leather with saddle stitching up.

C Gamba ad anello in tubo rettangolare sezione 70x30 mm.
Ring leg in rectangular pipe section 70x30 mm.

04 OAK | WHITE



- A** Schermo in melaminico agganciabile frontalmente al top scrivania.
Melamine screen to fasten frontally to the desk top.



- B** Top in melaminico spessore 30 mm con bordo in ABS.
Melamine top, 30 mm thick edged in ABS.
- C** Gambe centrali in metallo verniciato.
Central legs in painted metal.
- D** Accessori in metacrilato traslucido agganciabili alle paretine e agli schermi.
Translucent methacrylate accessories that hook onto the panels and screens.
- E** Allungo ambidestro integrato alla scrivania o indipendente con ante scorrevoli frontali.
Integrated two-way extension to the desk or for independent use with front sliding doors.

Dati Tecnici | Technical Data

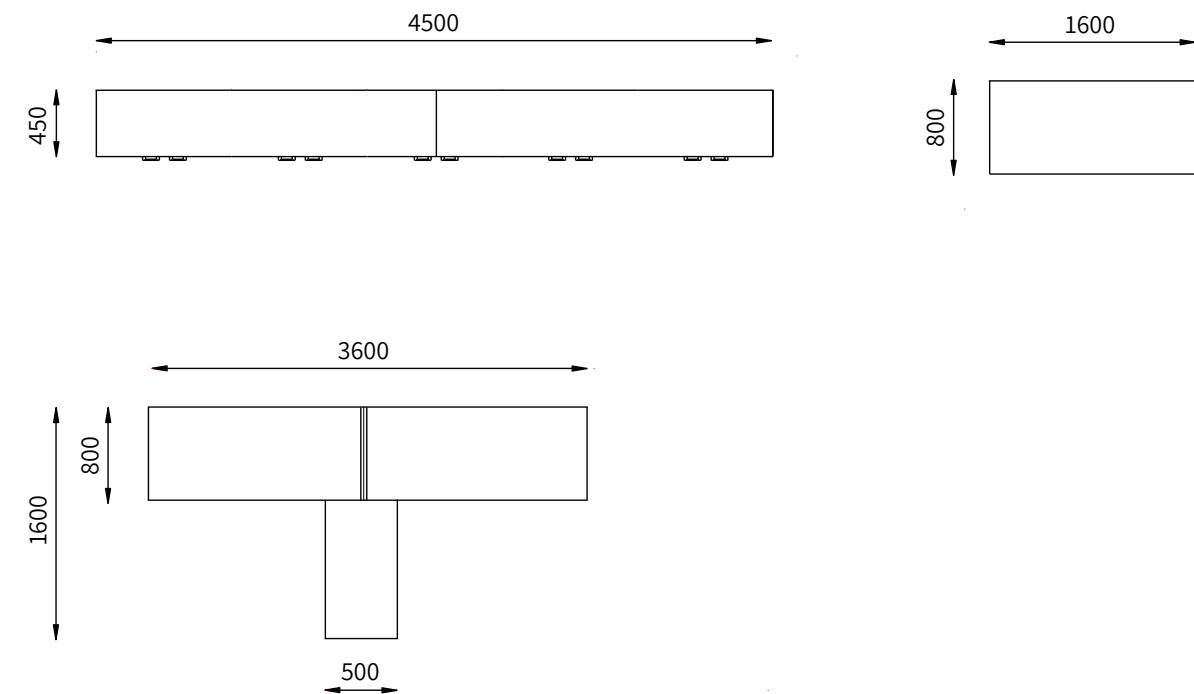

Finiture | Finishes

ARREDI | FURNITURE

Top scrivania e frontali | Worktops and frontals

MR30
Melaminico | Melamine
Rovere
Oak

Struttura | Structure

MB29
Melaminico | Melamine
Bianco
White

Gambe | Legs

EB48
Verniciato | Painted
Bianco
White

SEDUTE | SEATING

Struttura | Structure

Plastica | Plastic
Bianco
White

Seduta e schienale | Seat and back

Trevira | Trevira
Blu
Blue

05 OAK | ALUMINIUM





A Colonna centrale in melaminico ispezionabile, con vano tecnico.
Central column in melamine with technical compartment that can be inspected.

B Porta unità utilizzabile in due versioni: fissato al sottotop o mobile su ruote.
CPU rack in two versions: fastened under the top or movable on castors.

C Binario in alluminio anodizzato per aggancio di paretine, lampada e supporto monitor.
Anodized aluminium track for attachment of small walls, lamps and monitor supports.

Finiture | Finishes

ARREDI | FURNITURE

Top scrivania e frontali | Worktops and frontals

MR30
Melaminico | Melamine
Rovere
Oak

Struttura | Structure

MM21
Melaminico | Melamine
Alluminio
Aluminium

Gambe | Legs

EM41
Verniciato | Painted
Alluminio
Aluminium

SEDUTE | SEATING

Struttura | Structure

Plastica | Plastic
Bianco
White

Seduta | Seat

Trevira | Trevira
Rosso
Red

Schienale | Back

Rete | Mesh
Nero
Black



Versione con binario di aggancio in alluminio anodizzato più 2 passacavo in ABS color alluminio canalizzati per ciascun top.

Version with supporting rail in anodised aluminium and 2 cable ducts in ABS colour aluminium for each top.



Versione fascia tecnica composta da binario di aggancio e due sportelli passacavo longitudinali in alluminio anodizzato canalizzati.

Version with technical conduit composed by supporting rail and two ducted longitudinal doors in anodised aluminium.

Dati Tecnici | Technical Data

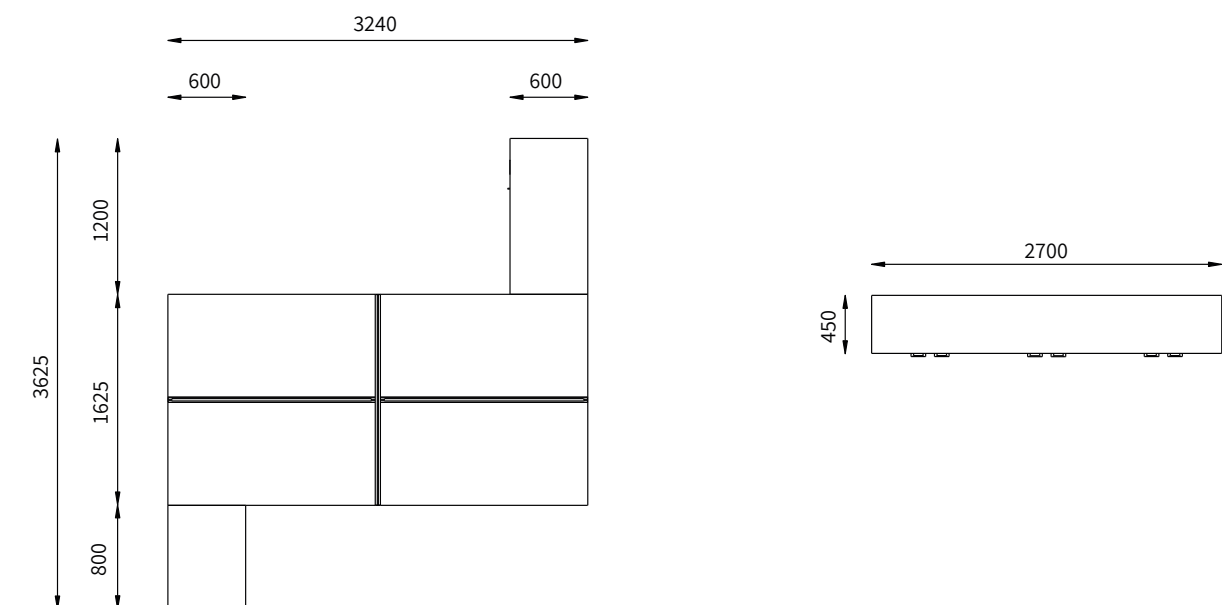

06 WALNUT | WHITE



A Composizione scrivania con allungo integrato.
Desk layout with integrated extension.

B Rivestimento frontale lana cotta ad alto spessore o in cuoio.
Front covering in thick boiled wool or leather.

C Fregio in acciaio inox lucido.
Frieze in polished stainless steel.



D Rivestimento schienale in cuoio lavorato a punto sella.
Back panel upholstered in saddle stitched leather.

E Distanziale in acciaio inox lucido.
Spacer in polished stainless steel.

Dati Tecnici | Technical Data

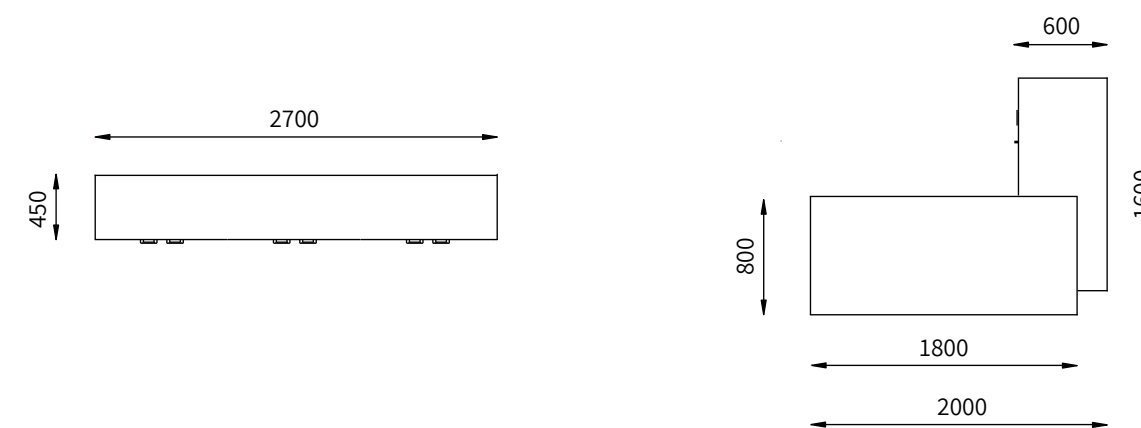

Finiture | Finishes

ARREDI | FURNITURE

Top scrivania e frontali | Worktops and frontals

MN31
Melaminico | Melamine
Noce
Walnut

Struttura | Structure

MB29
Melaminico | Melamine
Bianco
White

SEDUTE | SEATING

Fronte | Front

UV57
Lana cotta per cuoio | Boiled wool for thick leather
Verde
Green

Retro | Back

CN72
Cuoio | Thick leather
Nero
Black

07 OAK | WHITE





A Top e fianchi in melaminico da 30 mm con bordo in ABS.
Top and sides in 30 mm melamine edged with ABS.

B Schienale coprigambe in melaminico bianco o alluminio, spessore 18 mm.
Modesty panel to conceal legs in white melamine or aluminium, 18 mm thick.

C Cassetto opzionale porta cancelleria applicabile sottopiano.
Optional stationery drawer for fastening under the top.

Finiture | Finishes

Top scrivania e frontali Worktops and frontals

MR30
Melaminico | Melamine
Rovere
Oak

Struttura Structure

MB29
Melaminico | Melamine
Bianco
White

Gambe Legs

EB48
Verniciato | Painted
Bianco
White

SEDUTE | SEATING

Struttura Structure

Plastica | Plastic
Bianco
White

Seduta Seat

Trevira | Trevira
Rosso
Red

Trevira | Trevira
Nero
Black

Schienale Back

Rete | Mesh
Nero
Black

Dati Tecnici | Technical Data

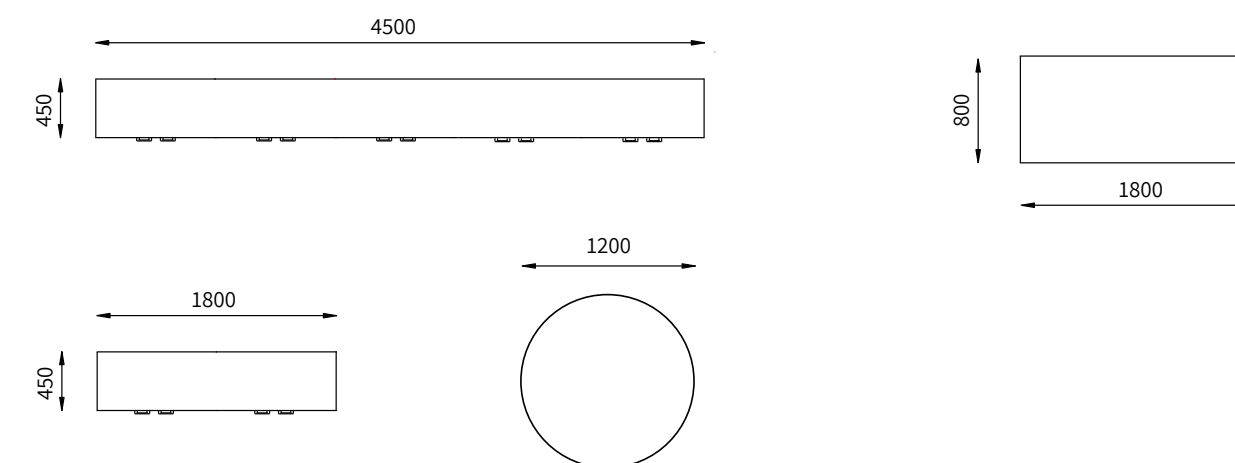

08 WENGÉ | WHITE



Dati Tecnici | Technical Data

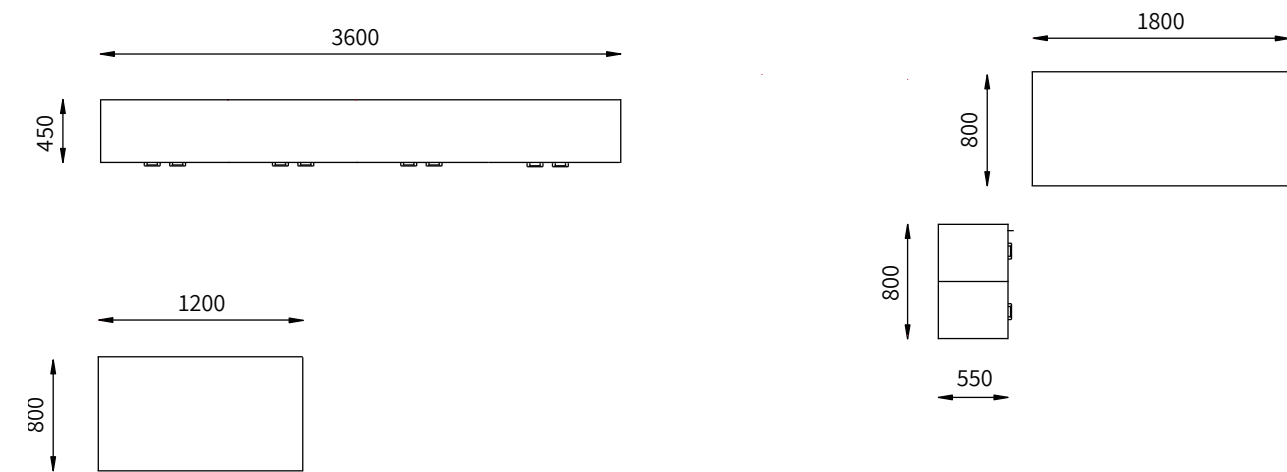

A Passacavo opzionale in ABS color alluminio.
Optional cable duct in ABS aluminium colour.

B Portacavi verticale opzionale color alluminio.
Optional vertical cable duct aluminium colour.

C Traversa canalizzata per il transito dei cavi.
Ducted crosspiece for cables.

Finiture | Finishes

ARREDI | FURNITURE

Top scrivania e frontali | Worktops and frontals

MQ23
Melaminico | Melamine
Wengé
Wengé

Struttura | Structure

MB29
Melaminico | Melamine
Bianco
White

Gambe | Legs

EB48
Verniciato | Painted
Bianco
White

SEDUTE | SEATING

Struttura | Structure

Plastica | Plastic
Nero
Black

Seduta e schienale | Seat and back

Trevira | Trevira
Verde Oliva
Olive Green

09 PEARL GREY | ALUMINIUM



Dati Tecnici | Technical Data

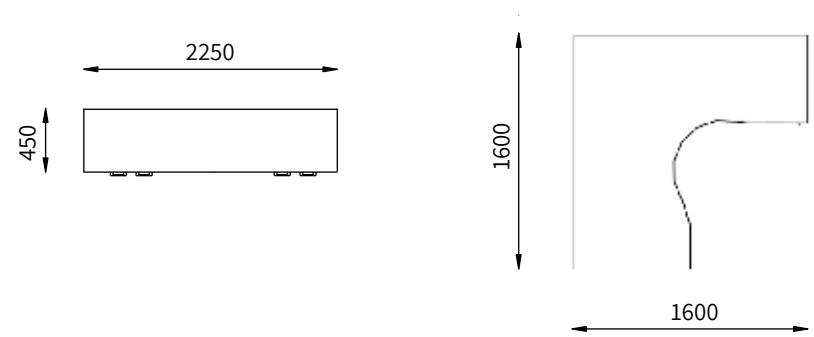

Finiture | Finishes

ARREDI | FURNITURE

Top e frontali | Tops and frontals

MP25
Melaminico | Melamine
Perla
Pearl grey

Struttura | Structure

MM21
Melaminico | Melamine
Alluminio
Aluminium

Gambe | Legs

EM41
Verniciato | Painted
Alluminio
Aluminium

Fronte | Front

CT86
Cuio | Thick leather
Tortora
Dove grey

Retro | Back

CJ83
Cuio | Thick leather
Bianco
White

SEDUTE | SEATING



A Coppia passacavi opzionali in ABS color alluminio.
Pair of optional cable ducts in ABS aluminium colour

B Maniglia da 110 mm in metallo cromato
110 mm handle in chrome-plated metal

C Cassetto in metallo con guida a rulli, attrezzabile internamente con divisori e porta cancelleria
Metal drawer with roller guides. Can be fitted with partitions and stationery tray.



TOP E ANTE TOP AND DOORS
Melaminico | Melamine

MQ23
Wengè | Wengè

MN31
Noce | Walnut

MR30
Rovere | Oak

MP25
Perla | Pearl grey

MB29
Bianco | White

STRUTTURA STRUCTURE
Melaminico | Melamine

MM21
Alluminio | Aluminium

MB29
Bianco | White



- A** Struttura elevabile elettricamente per scrivania singola. Gambe a T rovesciate in metallo verniciato. Escursione di 65 cm (da 64 a 129 cm). Regolazione continua con pulsantiera up&down. Velocità 30-40 mm/sec.

Electrically elevated structure for a single desk. Inverted T-shaped legs in painted metal. Lifting range of 65 cm (64 to 129 cm). Continuous adjustment with up & down push-button panel. Speed 30-40 mm / sec.

- B** Struttura elevabile elettricamente per system bench condiviso. Composta da quattro colonne a sezione rettangolare in metallo verniciato. Escursione di 65 cm (da 64 a 129 cm). Regolazione continua con pulsantiera up&down. Velocità 30-40 mm/sec.

Electrically elevated structure for shared system bench. Composed by four rectangular section columns in painted metal. Lifting range of 65 cm (64 to 129 cm). Continuous adjustment with up & down push-button panel. Speed 30-40 mm / sec.



Scrivanie elevabili

Salvaguardare la salute e il benessere di chi trascorre molte ore lavorative alla propria scrivania, è questo l'obiettivo della struttura elevabile elettricamente proposta tra le varie tipologie della collezione Team. Una soluzione versatile ed ergonomica che riduce il senso di fatica dell'operatore, diminuisce il tempo del lavoro sedentario e accresce benessere ed energia. Codutti propone la struttura elevabile nelle due versioni a scrivania singola con gamba T rovesciato oppure system bench condiviso con quattro colonne a sezione rettangolare. Per un ambiente ufficio attento alle esigenze del mondo lavorativo contemporaneo. Informazioni, prezzi e finiture disponibili sul catalogo Just in Time Codutti.

Elevating desks

Health and well-being of those who spend many hours working at their desk is our priority, that is why we propose electrically raised structure among the various models of Team collection. A versatile and ergonomic solution that reduces the operator's sense of fatigue, decreases the time of sedentary work and increases well-being and energy. Codutti offers the elevating structure in two versions – as a single desk with inverted T leg or shared system bench with four rectangular section columns. Effective solution for an office environment attentive to the needs of contemporary business world. Information, prices and finishes available on the Just in Time catalogue by Codutti.



TOP, GAMBE PANNELLATE E FRONTALI

TOP, PANELLED SIDES AND FRONTALS

Melaminico | Melamine

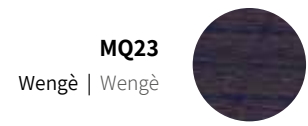

MQ23
Wengè | Wengè

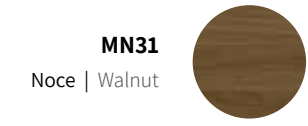

MN31
Noce | Walnut

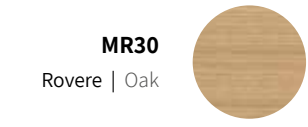

MR30
Rovere | Oak

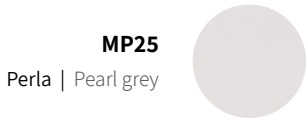

MP25
Perla | Pearl grey

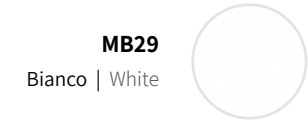

MB29
Bianco | White

GAMBE

LEGS

Metallo | Metal

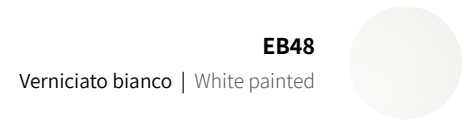

EB48
Verniciato bianco | White painted

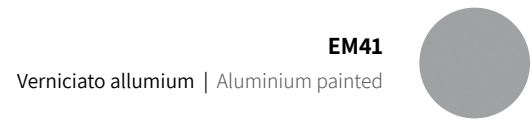

EM41
Verniciato alluminio | Aluminium painted

Il cuoio e la pelle sono materiali diversamente trattati, quindi diversa è la rifrazione della luce che determina il tono del colore. Le cuciture di pelle e cuoio possono presentare irregolarità nel tratto e variazioni di linea. Pertanto differenze di tono del colore e lievi imperfezioni nelle cuciture devono essere accettate quale segno dell'unicità e della cura artigianale del prodotto. Codutti Furniture S.r.l. si riserva di apportare qualsiasi modifica alle Collezioni presenti in questo catalogo ogni volta che lo ritenga opportuno.

Thick leather and thin leather undergo different curing processes. As a result, the surfaces refract light differently and this determines a variation in the shade of the color. Moreover, the stitching in both thick and thin leather may appear irregular. Any differences in the shade of color and slight imperfections in the stitching are the natural consequence of the craftsmanship involved in the manufacturing process, which makes each product unique. Codutti Furniture S.r.l. is entitled to bring any modifications on Collections included in this catalogue at any time, without previous notice.

STRUTTURA

STRUCTURE

Melaminico | Melamine

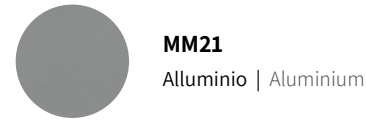

MM21
Alluminio | Aluminium

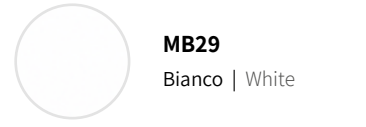

MB29
Bianco | White

SCRIVANIE | WRITING DESKS

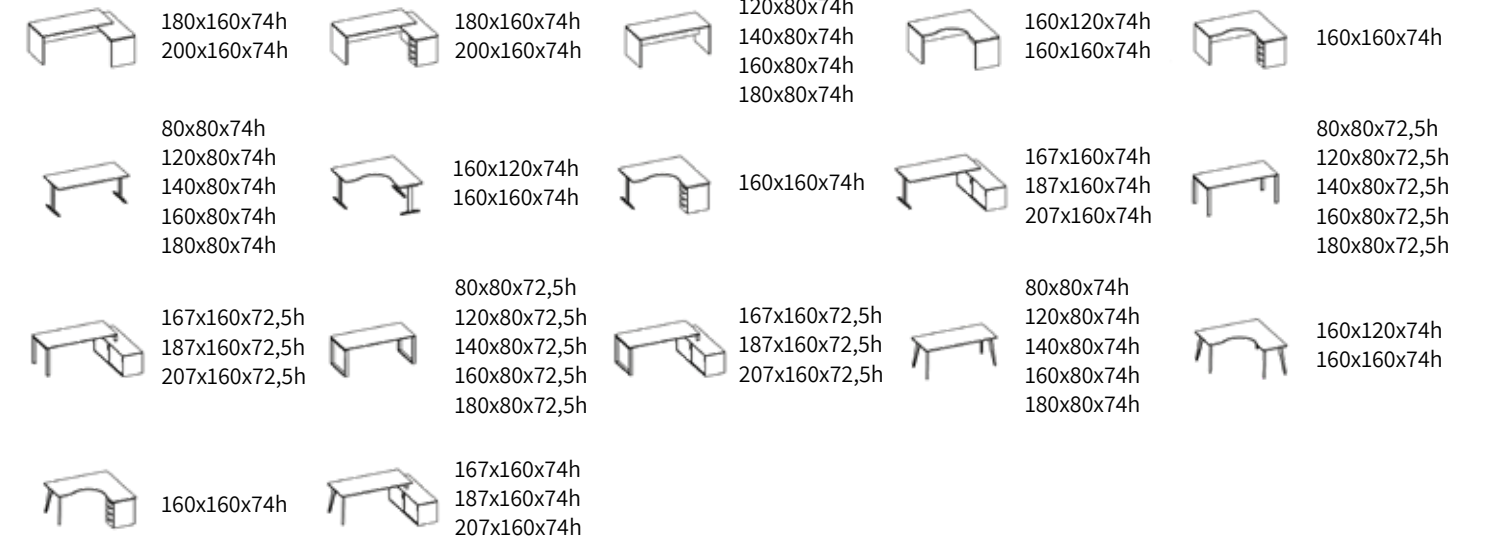

ALLUNGHI | EXTENSIONS

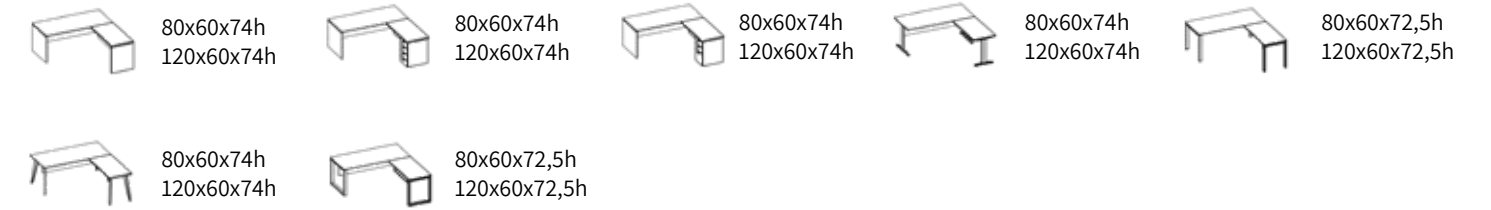

SCRIVANIE MULTIPLE | SYSTEM BENCH

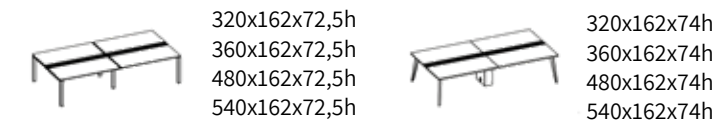

ARMADIETTI DI SERVIZIO | SERVICE CABINETS



TAVOLI RIUNIONE | MEETING TABLES

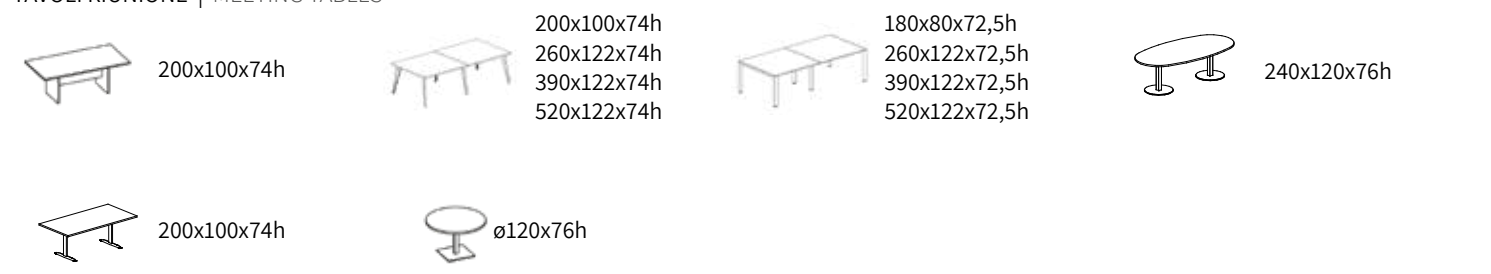

ARMADI | CABINETS

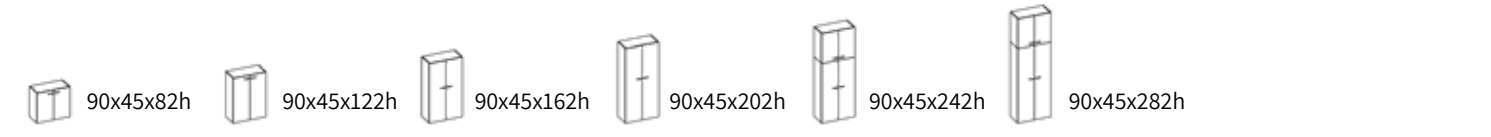

Rendered by

Andrea Macor Rendering
Alberto Codognotto | Kodocreation
Primastudio

Print

Treviso Stampa

Copyright® 2019
by Codutti Furniture S.r.l.

